



Technical and product information



OVERVIEW



NEWS

Alternators and starter motors



A/C SYSTEM

Compressors: development and causes of failure



FOCUS

Transmission: automation of a complex system



MARKET

More and more comfort with pneumatic suspensions



30.000
available products

150
product ranges



CERTIFIED
TecDoc®
DATA SUPPLIER

LinkedIn
M&D Group

meat-doria.com
hoffer-products.com

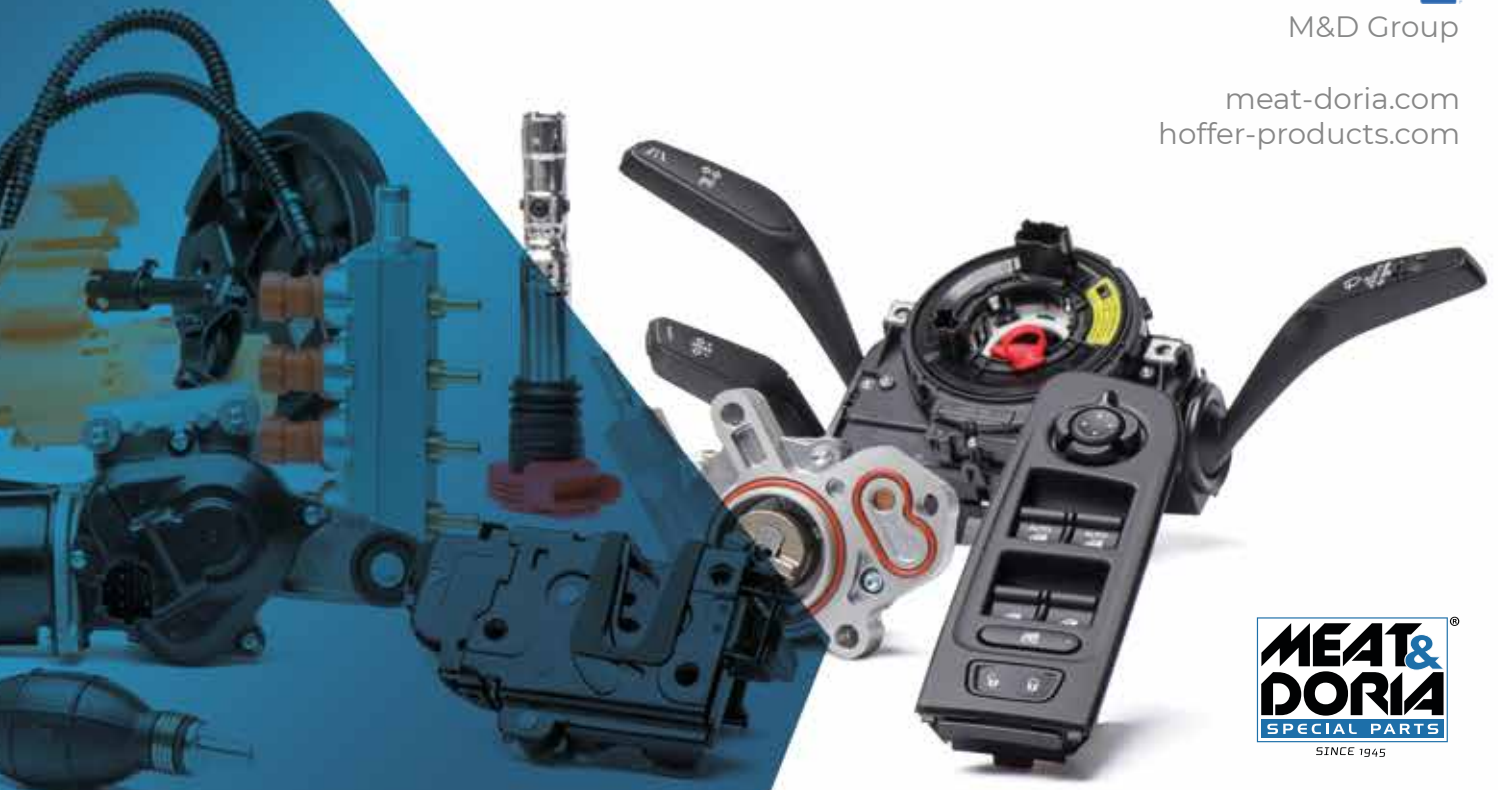

expertise
by **your side**

MEAT & DORIA
SPECIAL PARTS
SINCE 1945

HOFFER
PRODUCTS
SINCE 1999

SUMMARY



NEWS

Alternators and starter motors:
the *rotating heart* of the electrical system 4



A/C SYSTEM

Compressors: development and causes of failure 12



FOCUS

Transmission: automation of a complex system 18



MARKET

More and more comfort with pneumatic suspensions 20



PARTS

The full range 22

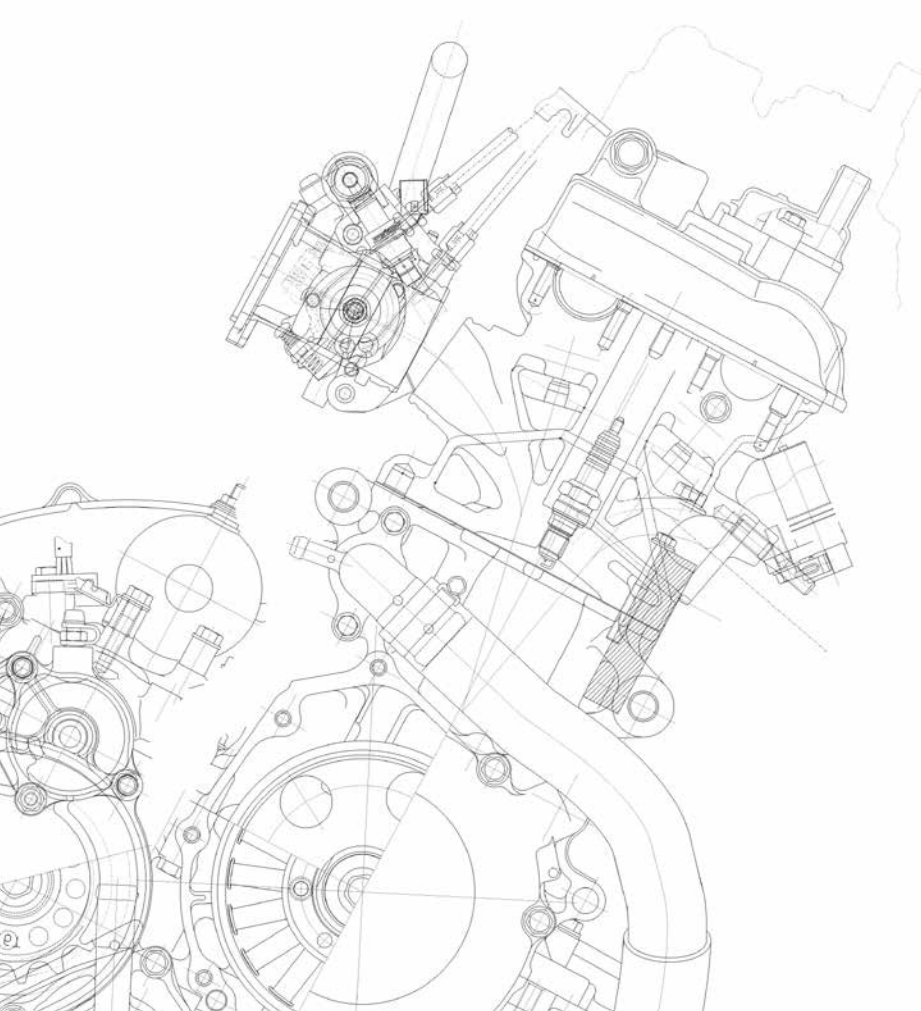

OVERVIEW

Editorial office and graphics:

M&D Group

Layout and printing:

Stamperia Artistica Nazionale S.p.A.

For more information:

marketing@meat-doria.com



NEWS



Alternators and starter motors: the *rotating heart* of the electrical system

The classic electrical system used on all vehicles has an operating voltage of 12V. This system is powered through a high capacity battery (from 30 Ah to 120 Ah on modern cars), and it supplies DC power to the entire vehicle.



The components and loads powered by the electrical system include:

- Lighting (headlamps, rear lamps, direction indicators and interior lighting).
- Windscreen wiper and window motors.
- Controllers.
- Actuators of various types (solenoid valves, throttles, recirculation valves, passenger compartment controls, automatic tailgate, etc.).
- Injectors, sensors and probes.
- The starter motor, used to start the internal combustion engine.

All these components draw powers during their operation. If the battery was not constantly recharged, these components would quickly discharge it. The recharging is performed by the **alternator**: a compact generator, driven by a drive belt running off the engine, which generates AC power.

Another essential component of the electrical system is the **starter motor**: it starts the internal combustion engine by turning a flywheel until the engine runs by means of its own power.

In short, the electrical system starts the engine, but the engine itself supplies power to the electrical system and keeps it charged. The two are therefore dependent on each other - neither can work properly without the other.

While the electrical system of a modern car is highly sophisticated, it always has the same components:

- **Battery**: this is the vehicle's "power reserve" - it stores energy and supplies it to all the electrical components.
- **Alternator**: this generates AC power from the rotary movement of the engine and converts it into DC power; it is the battery charger for the entire system. Most recent systems are also intelligent, since they charge the battery only when needed. This increases battery life and reduces fuel consumption, since the engine does not need to power the alternator all the time.
- **Electronic control unit**: this is the engine's brain; modern cars have multiple control units, each with its own specific function (engine control, comfort, safety, control of specific components like the automatic tailgate, lighting and ADAS).
- **Fusebox**: this protects the electrical system and its components from overcharging due to excessive absorption.
- **Voltage regulator or stabilizer**: integrated into the alternator, this prevents voltage peaks and drops at times of very high power draw (for instance, when starting the engine), as well as whenever the alternator is generating more power than required.
- **Intelligent battery sensor (IBS)**: on more recent cars, such as cars equipped with Start&Stop technology, it constantly monitors the battery

Exploded view of an alternator

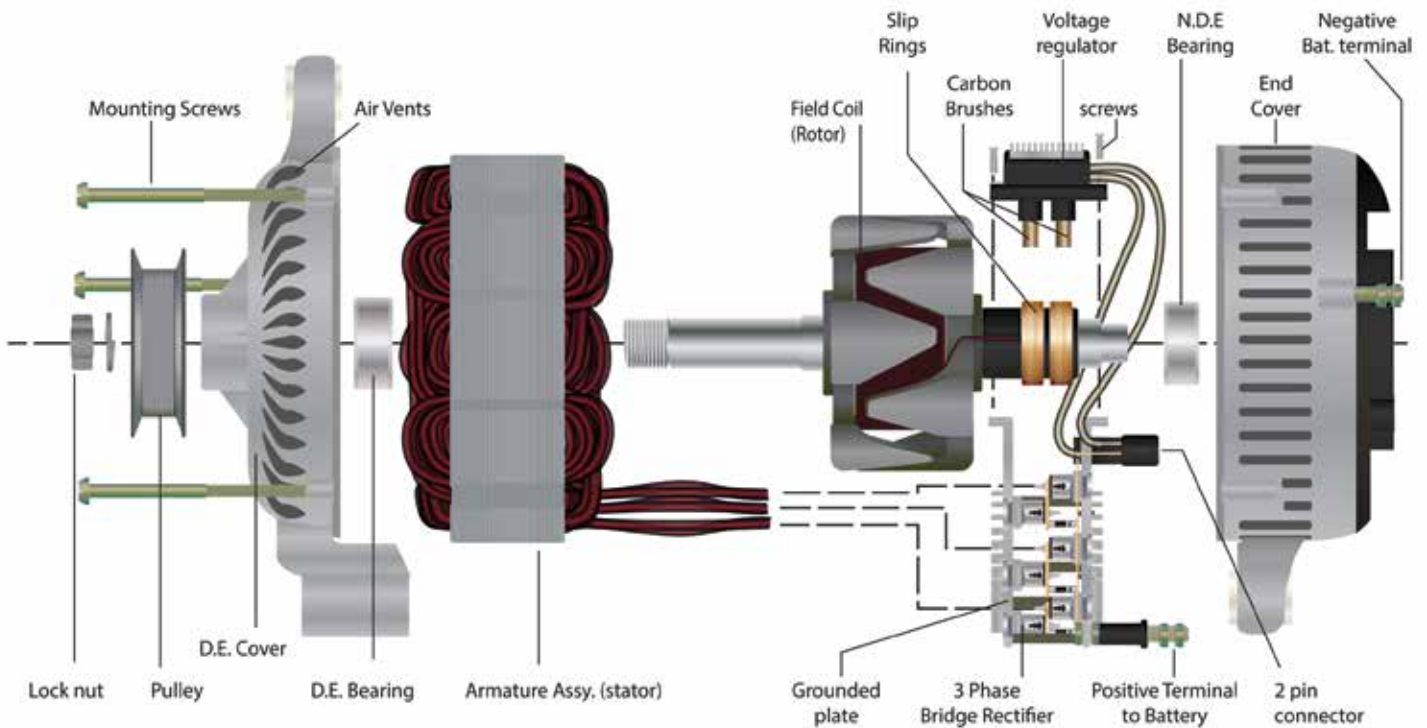

charge, condition and temperature. It is able to determine when the battery needs recharging and when it doesn't, which increases battery life.

- **Vehicle grounding points:** equipped with black, blue or green cables, these represent the negative pole of the electrical components, and are securely mounted to various points of the bodywork.

This article deals with **alternators** and **starter motors**, which M&D Group introduced into its catalog in the second quarter of 2021, with the high quality for which the company is known.

As we said, the alternator, mounted to the engine block, charges the battery and powers the vehicle's loads.

The **alternator** has the following components:

- **Casing:** made in aluminum, this protects the unit's moving parts. It is made of two parts, the front rotor side and the rear section with cover.
- **Pulley:** located at the front and driven by the service belt, it turns the rotor inside the alternator. It may be single, double or multi-groove (also known as a Poly-V pulley). It may also have a clutch, to enable its free rotation without engag-

ing in the direction opposite to that of the alternator. This prevents kickback, which affects the magnetic field, and also prevents the assembly failing if it seizes.

- **Core:** this is composed of the copper windings and the stator; the latter rotates inside the windings to create the magnetic field and thus generate the AC current.
- **Electrical components:** these are the diode bridge, which converts the AC current into DC, and the voltage regulator, which prevents voltage peaks and drops.
- **Plastic cover:** this protects the electrical components, and also contains the connectors, the positive terminals and the grounding points.





ALTERNATORS: TROUBLESHOOTING

DEFECTS	CAUSES	REMEDY
Alternator does not run	Broken connections	Check and restore the connections
	Faulty diodes	Check and replace the diodes if necessary
	Faulty energization circuits	Check the continuity of the energization circuit
	Faulty voltage regulator	Check and replace the regulator if necessary
Voltage under load lower than nominal	Voltage regulator tripped	Replace the voltage regulator
	Rpm lower than nominal	Check the rpm
	Voltage regulator improperly calibrated or faulty	Restore the nominal voltage by replacing the voltage regulator
Voltage too high or unstable	Over-energization limiter tripped	
	Faulty voltage regulator	Replace the voltage regulator
Winding temperature too high	Excessively unbalanced circuit	Check that the circuit is properly balanced
	Faulty windings	Check the windings
	Measurement system faulty	Check the sensors
Alternator noisy and vibrating	Not properly secured to the engine block	Check the mounting bolts are properly tightened down
	Incorrect belt tension	Check the balance, alignment with the pulley
Noisy bearings	Internal shaft bearing	Replace the internal bearing
	Faulty bearings	Check the condition of the bearings
Excessive bearing vibration	Machine out of alignment	Check and replace the bearing if necessary
	Unforeseen external loads	Check the alignment Check the coupling area
Warning light flashing	Alternator belt loose or slipping	Tighten down or replace the alternator belt
	Faulty battery contacts or regulator resistor	Adjust the regulator contacts or replace the resistor. Check the battery
Recharging light stays a light color	Cable D+ is short circuited towards ground	Eliminate the short circuit towards ground
	Rectifier faulty	Replace the regulator
	Header soiled	
Discharged or faulty battery	Short circuit in the DF cable or rotor winding	Check and repair/replace the alternator
	Discharged battery	Recharge the battery, check and replace as necessary
Traces of water and oxidization	Connections/cables faulty, loose or oxidized	Check the cables and secure or replace them as necessary
	Faulty sensor or warning light	Check the sensor and warning light
Pulley jammed	Water pump failed, puddles due to flooding, engine washed with a jet	Do not direct jets of water onto the alternator - it is an electrical component
	Pulley jammed as a result of impact or seized motor	Replace the pulley, check the operation of the motor

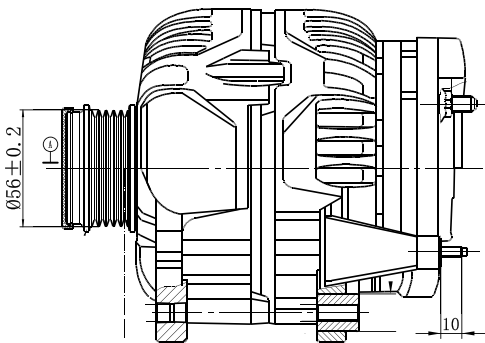
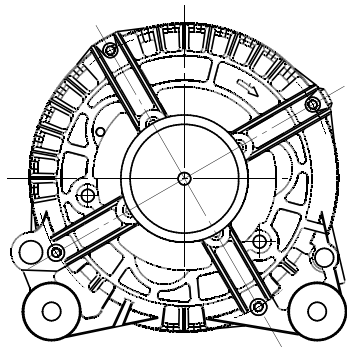

DESIGN OF AN ALTERNATOR

The alternator generates AC current, created by the alternation of positive and negative fields between the rotor and stator. It is also three-phase, since the poles alternate every 120° . The diode bridge neutralizes the negative magnetic field and normalizes the AC current into DC.

Since it is not stabilized, and thus presents voltage peaks and drops in relation to the speed of rotation and the magnetic fields, the alternator must be equipped with a voltage regulator (or stabilizer): this is located at the back of the alternator and, when working properly, ensures that the current output is a perfectly stable 14 V.

An alternator has a number of connectors on its back cover, each of which can provide supplementary information, including the **engine speed**, **alternator load** and **alternator status**.

For several years, car manufacturers have increasingly been offering 48 V Mild-Hybrid systems, which feature a number of innovations and advantages. This is a 48 V electrical system (with a correspondingly higher capacity battery), which works with both 12 V and 48 V components, with the advantage

that components previously actuated by the engine and its belt or camshaft now operate electrically at 48 V. Furthermore, the starter motor is replaced by a dynamotor, an advanced alternator with a higher power rating which starts the engine.

This all goes to improve the overall efficiency of the system by around 10-15% over a traditional IC engine with 12 V electrical system: in some cases, components like the water and oil pumps, turbo-charger and other are now electrical thanks to the availability of the 48 V circuit, which reduces the load on the engine and hence also fuel consumption.

The **starter motor** has the following components:

- **Casing:** made in metal and cast iron, it protects the motor's internal components. It is anchored to the base of the engine.
- **Electric motor:** this is a conventional single-phase motor.
- **Brushes:** located at the rear, they create the magnetic field that drives the motor.



SECTIONAL VIEW OF AN ALTERNATOR

- **Pinion:** this is a freewheel which, when driven, engages the crankshaft flywheel and turns it so that the engine starts.
- **Arm or fork:** this pushes the pinion forwards with a lever.
- **Return spring:** this returns the pinion to the standby position when the starter motor is not running.
- **Solenoid:** when energized, this moves the pinion outwards to engage it with the flywheel.

Exploded view of starter motor

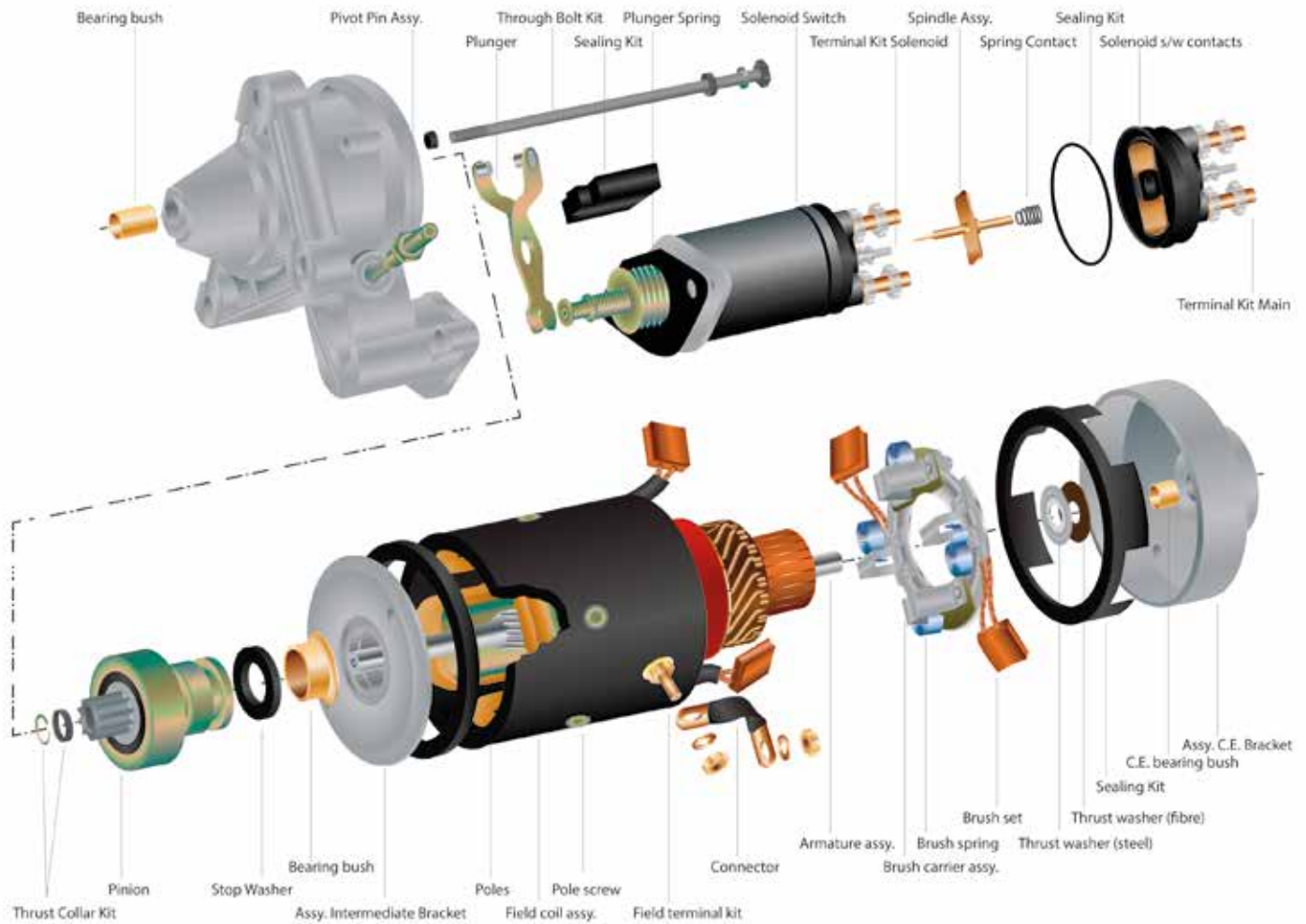

The **starter motor** has the following operating sequence:

1. When the driver turns the key or presses the ignition button, two control signals are sent to the starter motor: one to energize the solenoid, and the other to start the starter motor itself.
2. When the solenoid is energized, it retracts its shaft: the fork lever then moves the pinion outwards to engage it with the engine shaft flywheel.
3. Together with the solenoid signal, another one starts the starter motor which rotates the pinion.
4. The pinion rotates and moves outwards to engage the crankshaft flywheel, turning it until the engine starts.
5. Once the engine has started, the key is released: the solenoid is no longer energized and the pinion is retracted by the return spring on its shaft; at the same time, the starter motor stops running.

If the pinion were to remain engaged with the flywheel by mistake, the first acceleration of the

engine would spin the starter motor rotor too fast and damage it.

In the second quarter of 2021, M&D Group launched a number of products for this sector, with its characteristic approach of creating value for the entire distribution chain with quality products and thorough coverage of the market.





STARTER MOTORS: TROUBLESHOOTING

DEFECTS	CAUSES	REMEDY
Faulty cables	Insufficient current Discharged battery or faulty alternator	Replace and restore the electrical connections
Solenoid not working	The starter motor runs but engages, faulty solenoid or cabling	Disconnect the battery cable from terminal 30 and make direct contact with the battery. If the motor runs, the solenoid contacts are dirty or corroded Check the battery voltage Check the connections to ground
Starter motor pinion does not engage	Flywheel gear teeth defective due to wear, dirt and friction	Replace the starter pinion Check the flywheel
The motor runs intermittently or not at all	Discharged battery	Check the battery charge / replace the battery
	Faulty power supply due to loose or oxidized connections	Check the battery terminals and connections, tighten down
	Carbon brushes jammed	Clean the brushes and guides on the mount
	Carbon brushes worn	Replace the brushes
	Header soiled	Clean the header
Starter motor pinion does not rotate forwards	Header scored or burnt	Overhaul/replace the starter motor
	Faulty induced field or winding	Overhaul/replace the starter motor
	Dirty or damaged shaft/thread	Overhaul/replace the starter motor, as necessary
The starter motor does not run when the starter switch is operated	Faulty solenoid	Replace the solenoid
	Worn or damaged return spring	Replace the return spring
	Ground cable/connection broken	Check the battery terminals and connections Clean the battery terminals and clamps
	Insufficient power supply due to loose or oxidized connections	Establish a connection which is not connected with the current between the starter motor, battery and ground Measure the battery voltage
The starter motor does not run, or runs slowly and does not start the engine	Discharged battery	Check the battery, recharge or replace it as necessary
	Carbon brushes worn	Replace the brushes
	Carbon brushes jammed	Clean the brushes and guides on the mount
	Weak springs	Replace the springs
	The carbon brushes are not making contact	
	Header soiled	Clean the header
The pinion does not move outwards	Header scored or burnt	Overhaul/replace the starter motor
	Faulty induced field or winding	Overhaul/replace the starter motor
	Pinion or thread tilted, soiled or damaged	Overhaul the starter motor and replace it if necessary
	Faulty magnetic switch	Replace the magnetic switch
	Worn or broken return spring	Replace the return spring

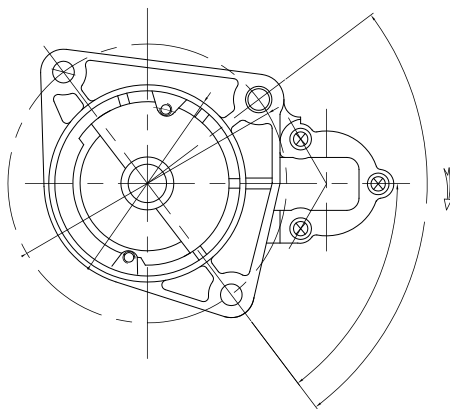
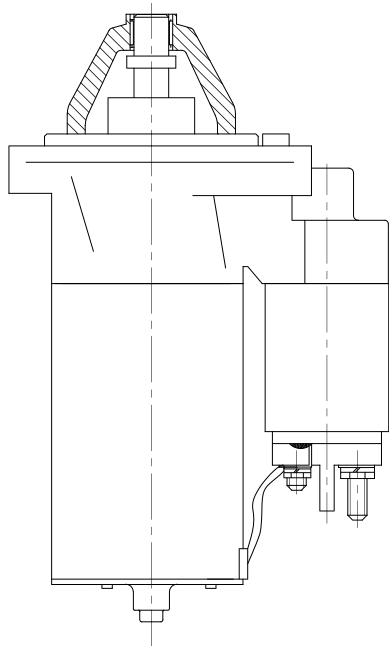

DESIGN OF A STARTER MOTOR



SECTIONAL VIEW OF A STARTER MOTOR

enables us to immediately offer a catalog that covers the market, as well as ensuring interchangeability wherever possible.

- Finding the best testing process, to protect our clients and customers: we test the quality of our products on test benches that simulate the operation of starter motors and alternators throughout their use, including stress tests.

These machines were essential to the sample selection phase, but they are even more so to our after sales service. Indeed, we must be able to supply a response as precise as possible to warranty claims, including detailed test reports with relevant values. In addition, our test benches are essential to handling non-conformities, since they enable us to test every feature of products subject to claims.

For the rotary machines, we focused on the following points:

- Finding products of the highest quality, thanks to close collaborations with the major manufacturers of OEM starter motors and alternators and the work of our R&D department, which supervised every step of the design and production process: only the usage of components of highest quality (diode bridges, pulleys, pinions and voltage regulators) can guarantee durable performance over time.
- Setting the best price: by carefully designing and optimizing all processes from the very start, M&D Group is able to offer outstanding value for money.
- Finding the best optimization of the range: this

Thanks to the attention we dedicate to every aspect of our processes, M&D Group is today able to offer a solid and complete range of products: every item is tested prior to sale, to ensure our excellent quality standards. Finally, we also pay careful attention to packaging: our products ship in tailor-made packaging, for two reasons - on the one hand, to protect the product adequately, and on the other, to use as little plastic as possible, in the interests of environmental sustainability.



A/C SYSTEM

Compressors: development and causes of failure

Air conditioning systems are closed loop circuits, consisting of five main components: the **compressor**, the **condenser**, the **dryer filter**, the **expansion valve** and the **evaporator**. These components are connected by fluid lines and controlled electronically using sensors.

The circuit is filled with fluid coolant, driven by the compressor through a path that causes sudden changes of state and, as a result, temperature.

The design of AC compressors has improved over the years. On the one hand, they have been made more **eco-friendly**: for instance, more ecological coolants are now used – the most recent type being R1234yf, designed to be less polluting and as little flammable as possible – and the

circuit is fitted with gaskets which prevent gas leaks; on the other, they are now more **powerful and efficient**: modern compressors are ever more compact and silent, while also being able to handle increased coolant flow rates, thus improving their performance.

In addition, with the advent of hybrid and electric vehicles, the compressor is one of the components most affected by technological advances: the compressor is 100% electric in such vehicles, and it is no longer driven by the utility system belt. This is enabled by a high voltage system (at least 48 V for mild hybrid vehicles and up to more than 600 V for full electric vehicles), which carries the amps required by the fully electric drive.



“ With the advent of hybrid and electric vehicles, the compressor has become one of the components most affected by technological advances. ”

Which hybrid and electric technologies are currently on the market?

- **Micro hybrid:** this type of hybrid system is called “micro” since it does not have its own electric motor. Instead, it is equipped with a starter/generator connected to a small supplementary battery, which powers the Start&Stop system. Micro hybrid systems do not increase the power of the vehicle, nor do they enable driving in electric mode, but they slightly contribute to fuel efficiency. Such cars include the Fiat 500 and Fiat Panda Hybrid.

- **Mild hybrid (MHEV):** this is one of the most common hybrid systems, thanks to its low cost and adaptability. A separate battery powers a small electric motor which only runs at ignition and when driving at low speeds, and then only for a few hundred meters. Furthermore, the engine is started by the motor generator (thus making the start of the engine smoother, and increasing the overall efficiency), while advanced strategies are employed in deceleration, including shutting down the engine (coasting) and recharging the motor generator, by recovering kinetic energy from braking. Such cars include the Kia Stonic, almost all Land Rovers, and medium-high range German cars like the BMW Series 3 and Mercedes Class C.
- **Full hybrid (FHEV):** this type is designed for full electric drive, thanks to the presence of an electric motor capable of powering the entire car. Both the motor and the battery are larger than



those used on mild hybrid vehicles. Depending on the power demand, an FHEV motor can run either alone or in combination with the internal combustion (IC) engine. The battery is charged by the IC engine and by kinetic energy recovery from braking. Such cars include the Toyota C-HR, Yaris Cross-Active and Hyundai Kona.

- **Plug-In hybrid (PHEV):** this is another type employing an electric motor with battery. The special characteristic of plug-in hybrid cars is that they are equipped with an electric charging port and less powerful IC engine. The electrical power, obtained when recharging enables more advanced cars of this type to drive up to 120 km in full electric mode, and the motor also contributes torque and power in hybrid mode. This range is made possible by the use of high capacity batteries (from 10 to 20 kW). Such cars include 4xE Jeep models, but they are also featured in nearly all model ranges of the major manufacturers.
- **Full electric:** as the name indicates, these are totally electric cars, whose drive train is equipped with one or more electric motors. In addition, all the vehicle's equipment is electric and no longer driven by belts and chains,

thanks to the presence of a battery pack with a capacity of over 50 kW in some cases – and such cars require a dedicated cooling system.

For hybrid motor cars, the air compressor is an essential component. Indeed, it is not only needed for passenger compartment climate control, but also for effectively cooling the battery pack and any supplementary controllers, such as the drive train and pressure converter controllers. Since they are subject to considerable stress, these components tend to overheat.

But that's not all: the point is that any component only performs optimally in a given temperature range. This is why the compressor is so essential, and why it must always be operational and in optimal working condition.

What are the causes of compressor failure?

Compressors, whether in hybrid or electric systems, fail for the same reasons as any others, with the added complication that, since the system is subject to heavier loads, such failures may be more frequent and require immediate repair.

The main causes of failure are:

1. **Insufficient or lacking lubrication:** since it has parts in continuous movement, a compressor must be kept lubricated at all times with oil with specific characteristics that can mix with the gas.
2. **Defective expansion valve:** the expansion valve is responsible for transforming the coolant from the liquid to the gas phase. It is a component that requires careful inspection, since a faulty valve can cause the compressor to fail.
3. **Overpressure:** a blockage in the compressor or other components (dryer filter or condenser, among others) may

result to excessive strain and failure.

4. **Lack of seal:** this can easily happen, caused by oil seals and gaskets no longer being able to provide an effective seal. The result is that the compressor runs with no load and fails prematurely.
5. **Humidity or acid in the circuit:** water, in any form (solid, liquid or gas), creates humidity. Humidity forms an acid solution with the coolant, which can erode the circuit's internal components like the compressor, evaporator, and condenser. In the case of an electric compressor, there is even the risk of electric shock.
6. **Dirt in the circuit:** metal shavings or pieces of filter material in the circuit can cause blockages and over-stress the components, causing them to fail.
7. **Electrical faults:** a malfunction of any of the compressor's electrical components (since the compressor has a lot of on-board electronics, especially in more recent models) can cause a failure and require replacement of the compressor.
8. **Improper mounting to the motor assembly:** it is essential that, when first installed or replaced, the compressed air compressor be perfectly aligned with the service belt and that the belt be properly tensioned. Over-stressing and out of axis installation can damage the pulley or its shaft, necessitating replacement of the entire assembly.

When replacing a compressor, to avoid the problem recurring, proceed as follows:

- **Thoroughly wash the system**, so to eliminate all the possible humidity and impurities from the circuit with a prolonged vacuum.

- **Replace all soiled components** (filters and valves).
- When recharging the circuit, **pay attention to the potential presence of fluid in the compressor**, as this can cause it to malfunction: if liquid directly enters the piston block, the entire unit can fail. It is important to always check that the expansion valve is in good working condition, so that it can guarantee the phase change from liquid to gas.
- **Recharge the system** at the high pressure side.
- **Pay attention to the manufacturer's instructions** and follow them scrupulously.

In addition to the above precautions, on hybrid and electric vehicles:

- **Shut off the electrical equipment and disconnect the battery.**
- **Take all measures to prevent the circuit restarting.**
- **Check that the system is not live.**
- **Ground and short circuit it.**
- **Protect yourself against adjacent live equipment.**



When working on high voltage electrical equipment, **all work should be done by a qualified technician only, operating in a properly equipped workshop.**

KRIOS AC, the leading brand of air conditioning spare parts, **offers a full, strategically optimized range of products to satisfy the requirements of nearly all European vehicles.**

Our strong points:

- Over 1,350 air conditioning compressors, active and available in stock, for cars, earthmoving and agricultural equipment, commercial vehicles, and

trucks – with 15 models specifically for hybrid and electric vehicles.

- Over 230 models of fan, with 15 for industrial vehicles and earthmoving equipment.
- Over 190 models of resistor.
- Over 110 models of regulator.
- Over 45 models of electrical actuator.
- Over 80 models of pressure switch.
- Over 145 types of expansion valve, 30 of which are for industrial vehicles and earthmoving equipment.
- Over 210 models of filter, cartridge and battery, with 50 for industrial vehicles and earthmoving equipment.

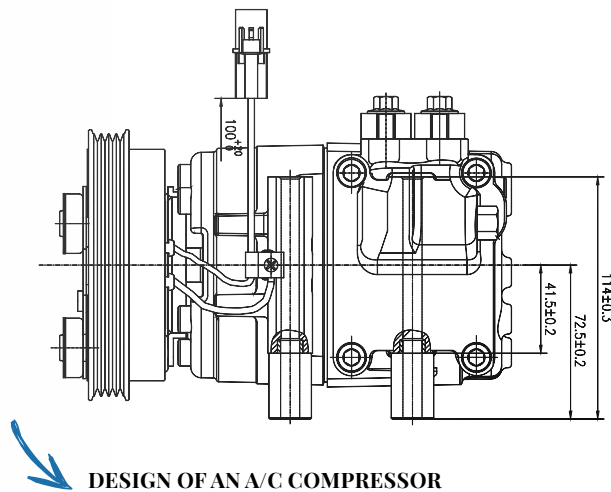
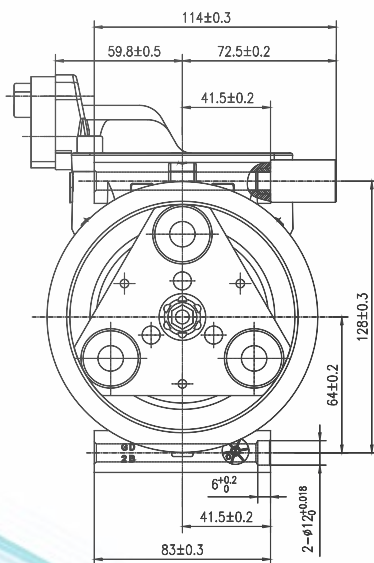

DESIGN OF AN A/C COMPRESSOR

The **KRIOS AC** brand, furthermore, has established **strategic synergies with large OEMs**, including Schrader Sensata, Biotron, Hanon System and Halla Holdings.



Meat&Doria / Hoffer: K11525
Krios AC: 1.1525



Meat&Doria / Hoffer: K12154A
Krios AC: 1.2154A



Tests and controls

All components in our product range must pass **over 30 rigorous quality tests**, including:

- 2 tests in the climate chamber;
- 3 pulley speed performance tests;
- 1 coolant seal test;
- 11 open/close cycle tests;
- 1 temperature test;
- 2 vibration resistance tests;
- 1 pressure shock test to check the seal of the compressor;
- 2 external saline mist pressure tests;
- 8 high performance duration tests on the bench;
- 1 internal inspection for cleanliness.

Furthermore, in most KRIOS AC aftermarket compressors, the oil they contain is double filtered, as specified for original equipment.



Customer service - Technical Team Krios AC

Tel: 011 647.40.57 int. 5

Mail: helpdesk@kriosac.it

Skype: helpdesk.kriosac



FOCUS

Transmission: automation of a complex system



“ Robotic and automatic transmissions have a number of supplementary components, without which automation and control would not be possible. ”

A vehicle's transmission transforms the potential energy of the engine into kinetic energy, which is then turned into the drive power that moves the vehicle.

Depending on how they work, there are three basic types of transmission:

- **Manual:** the option installed on most cars, this must be operated by the driver;
- **Robotic:** similar to a manual transmission in terms of the sequence of steps used to operate it, but the steps are automated by a dedicated

controller. The controller controls electric or hydraulic actuators which disengage the clutch disk, change the gear and then re-engage the clutch. In detail, the transmission controller sends a signal to the engine controller to facilitate the gear change: torque delivery is interrupted temporarily and the engine speed is reduced to assist shifting up, or increased when shifting down.

- **Automatic:** in this case, everything is completely automated, using a torque converter or double clutch, or, for continuously variable transmissions, a pair of belt-driven pulleys. The gear change, handled by the mechatronics, is fast, efficient and hardly noticeable.

A conventional manual transmission has no electronics: the drive is transmitted by the two shafts with the gearwheels and synchronizer. Robotic and automatic transmissions, on the other hand,

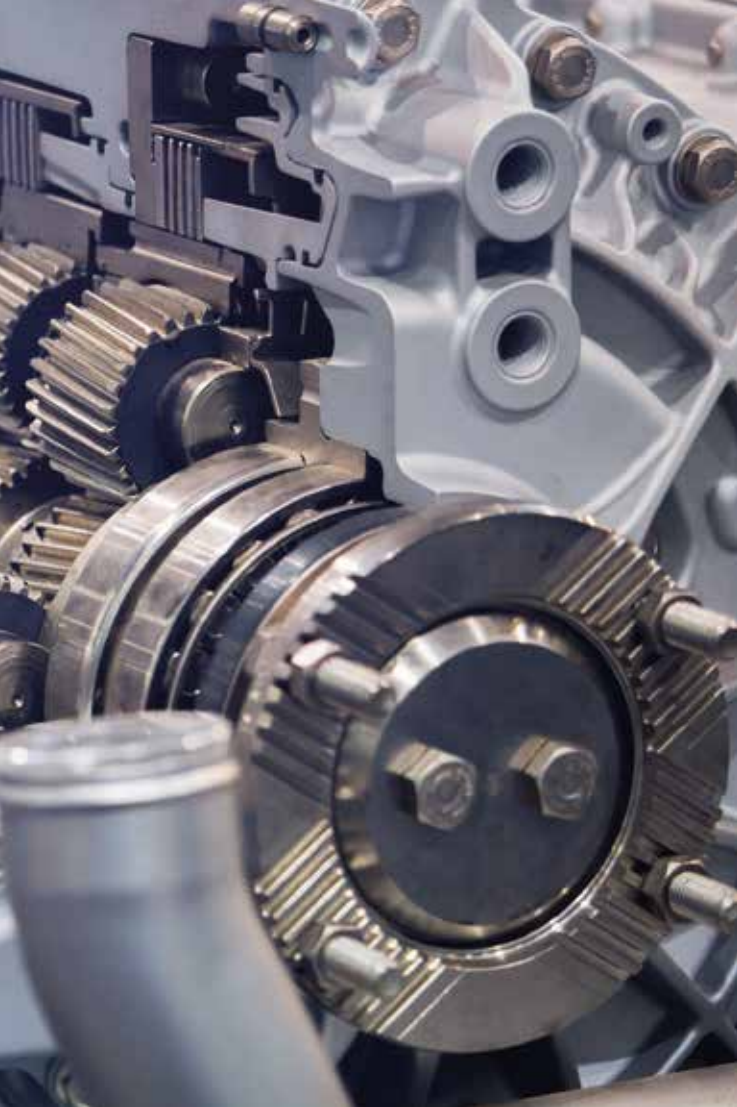

Due to their continuous duty, these components are subject to wear and are easily damaged, making the transmission imprecise and, in the worst case, causing it to fail.

M&D Group, following detailed analysis and thanks to its synergies with its clients, offers one of the most complete ranges of transmission components, and guarantees availability in stock of the parts most prone to malfunction and failure. The catalog includes the following product categories:

- **transmission actuators;**
- **transmission control modules;**
- **gear actuator motors;**
- **clutch actuators;**
- **module kits;**
- **actuator kits;**
- **automatic transmission kits;**
- **actuator valve kits;**
- **electric motor kits;**
- **accumulators;**
- **power unit kits.**

have a number of supplementary components. Without these components automation and control would not be possible. The following components are present in addition to the above:

- **Transmission actuator:** this engages the gears; double clutch transmissions have two of these, one for the even gears and one for the odd gears.
- **Transmission control module:** this handles gear selection. It is a mechatronic component with motorized and electronic sections.
- **Gear actuator motor:** this has the same purpose as the transmission actuator, but is electric rather than pneumatic.
- **Clutch actuator:** on robotic transmissions, this operates the clutch during gear changes.
- **Accumulator:** this is a reservoir partly filled with gas which, with its internal membrane, regulates the oil pressure in the automatic transmission.



MARKET

More and more comfort with pneumatic suspensions

“ M&D Group now offers suspension compressors and valve manifolds in addition to its existing offering of level sensors.

”

Suspension is essential on cars for two main reasons: **controlling the set-up**, because good handling makes the vehicle more predictable when steering, and **comfort in the passenger compartment**, since it makes the drive smoother.

Pneumatic suspensions are the best solution in terms of technology and comfort; this is why M&D Group has decided to invest in the development of suspension products. Indeed, due to its complexity, the system is not composed merely of the four shock absorbers, but rather of a complete set of electronic and pneumatic components working together in synergy.

What, then, are the components of a pneumatic suspension system?

- **Air shocks:** there are four of them, in place of the more traditional helical spring shocks. The

shock absorbing element is no longer a spring, but rather an air chamber inside the shock itself. However, a traditional shock absorber is still present, with the purpose of damping the vehicle's tendency to pitch and roll.

- **Electric compressor:** this drives air into the circuit to keep the shocks inflated and able to dampen shocks.
- **Valve manifold:** this distributes the air arriving from the compressor. It monitors the individual shocks to determine how much air should be sent to them, depending on the stiffness required for each unit.
- **Accumulator:** to prevent the compressor having to run continuously to keep the shocks inflated, this stores enough air to keep the circuit charged.
- **Level sensors:** these are fitted to each wheel to monitor the extension of the shocks at all times.

Pneumatic suspensions are active systems that respond in real time to:

- **The type of surface:** the amount of damping provided by the shocks depends on whether the road surface is asphalt or not.



Meata&Doria: 58025
Hoffer: H58025

- **Vehicle set-up:** the system can prioritize comfort or sports car handling, as the driver prefers; the amount of air in the shocks determines how hard the suspension is.
- **Height control:** as well as active damping control, pneumatic suspensions allow the driver to set the height, which may vary by as much as several inches. This significantly changes the performance of the vehicle, by lowering the body to reduce its aerodynamic profile, or increase its offroad capability by raising it.
- **Load transfer:** when the car suddenly accelerates, steers or brakes, the load distribution changes very quickly. Instantly hardening the suspension, on the axle or side to which the load is shifting, responds to the vehicle's changing set-up, and thus improves its road holding.

These active adjustments are made possible by a number of features: suspension **sensors**, the

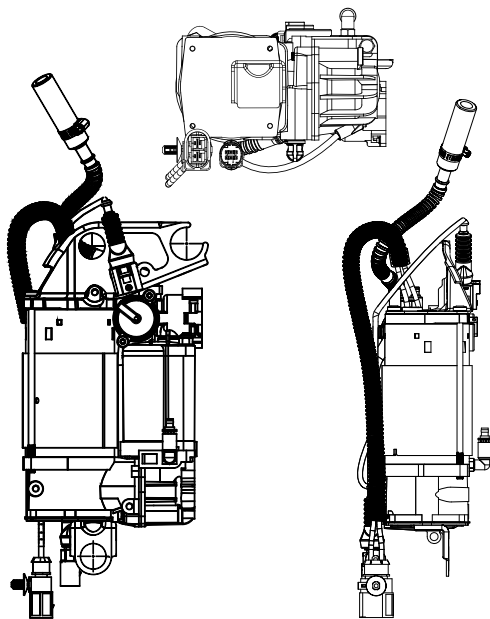

DESIGN OF A SUSPENSION COMPRESSOR

i

Tests

All our compressors are individually tested to ensure that they offer the highest possible level of reliability.



Electrical testing: each compressor is tested for its nominal and operating voltage, standby and peak load, both for the compressor itself and the valve manifold, separately.



Pneumatic testing: this tests the maximum pressure the compressor can handle, the time required to pressurize the entire system and the time required to depressurize it.



Noise testing: since the compressor is a comfort-related component, its running noise is also tested. The maximum allowed noise level is 85 dB.

driver's preferred **set-up**, and the **extension or compression of the shocks**, achieved by regulating the air flow to them.

Since pneumatic suspensions are always active, they are subject to a high level of wear, that aggravates the complexity of the system itself. The dampers and shocks themselves must be checked and replaced as often as traditional shock absorbers. The compressor is the most robust component in the system; however, if the shocks are leaking, the compressor will run continuously in response to the continual demand for air, and will be damaged by excessive wear.

M&D Group now offers ranges of suspension compressors and valve manifolds in addition to its existing level sensors, to satisfy the requirements of nearly all European vehicles.



PARTS

Over 30.000 refs.

The full range

ENGINE MANAGEMENT

Over 2100 refs.

- Idle speed controls
- Relays and components
- Injectors
- Electronic control units
- Throttle bodies
- Cohlne
- LPG / CNG
- Pressure regulators
- Electrical small parts
- Mechanical small parts and kits
- Air intake manifold modules
- Cable harness kits

EMISSION CONTROL

Over 1800 refs.

- EGR valves
- Mass airflow meters
- Mass airflow inserts
- Air pumps and valves
- Electrovalves
- Fuel vapour valves
- AdBlue systems

IGNITION COILS AND MODULES

Over 600 refs.

LIGHTING AND COMFORT

Over 3700 refs.

- Steering column switches
- Brake light, reverse light, hazard light switches
- Power window switches
- Level sensors
- Xenon light control units
- Head lamp switches
- Wiper motors
- Window wiper systems
- Windscreen wiper linkages
- Door lockers
- Airbag control modules and clock springs
- Steering locks
- Washer pumps

FUEL PUMPS

Over 2100 refs.

- Fuel supply units
- Fuel pumps
- Mechanical fuel pumps
- High pressure pumps
- Fuel level sensors
- Fuel pump accessories

TURBOCHARGERS

Over 2000 refs.

- Turbochargers
- Core assemblies
- Variable geometries
- Oil pipes
- Air hoses
- Recirculating air valves
- Gaskets
- Wastegates

VACUUM PUMPS

Over 200 refs.

- Vacuum pumps
- Air pump repair kits

STARTER SYSTEM

Over 2100 refs.

- Alternators
- Starters
- Pulleys
- Starter drives
- Electromagnets
- Voltage regulators
- Rectifiers
- Brushes



MECHANICAL & ENGINE COOLING Over 700 refs.

- Oil coolers
- Oil valves
- Camshaft phaser solenoid valves
- Steering pump repair kits

COOLING SYSTEM Over 1000 refs.

- Thermostats
- Thermal systems
- Water flanges and hoses
- Oil hoses
- Electric water pumps
- Expansion tanks

SENSORS Over 5000 refs.

- Knock sensors
- Throttle position sensors
- Acceleration pedal sensors
- Camshaft and crankshaft sensors
- Torque sensors
- Pressure sensors
- Parking sensors
- Oil level sensors
- Exhaust gas pressure sensors
- Exhaust gas temperature sensors
- Temperature sensors
- ABS sensors and units
- Fuel pressure sensors
- Oil pressure switches
- Brake pad wear sensors
- Brake booster pressure sensors
- NOx sensors
- Pedal stroke sensors
- TPMS sensors

OXYGEN SENSORS Over 750 refs.

DIESEL PARTS Over 1000 refs.

- Common rail pressure sensors
- Common rail pressure regulators
- Hand primer pumps
- Heating elements
- Injectors
- Injector repair kits
- Pump repair kits
- Nozzles
- Shaft pumps
- Oil seals
- Gaskets
- Fittings
- Other

AIR CONDITIONING Over 3150 refs.

- Compressors
- Control valves
- Viscous fan drives
- Pressure switches
- Viscous clutches
- Expansion valves
- Dryer filters
- Cabin fans
- Resistors and regulators
- Actuators

FILTERS Over 2100 refs.

CARBURETTOR KITS 430 refs.



NEWS

Alternators and starter motors:
the *rotating heart* of the
electrical system



A/C SYSTEM

Compressors: development and
causes of failure



FOCUS

Transmission: automation
of a complex system



MARKET

More and more comfort
with pneumatic suspensions



Technical and product information



OVERVIEW



www.meat-doria.com
www.hoffer-products.com